

引线型编带规格 (适用标准 JIS C 0806-2)

图 1



图 2



图 3

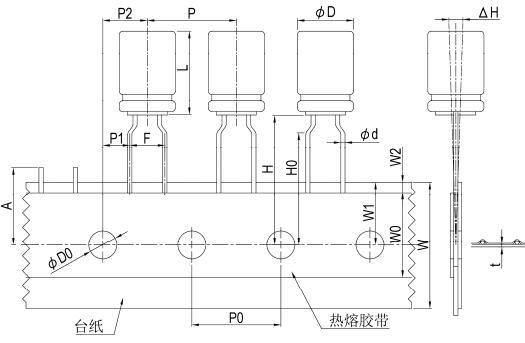

图 4

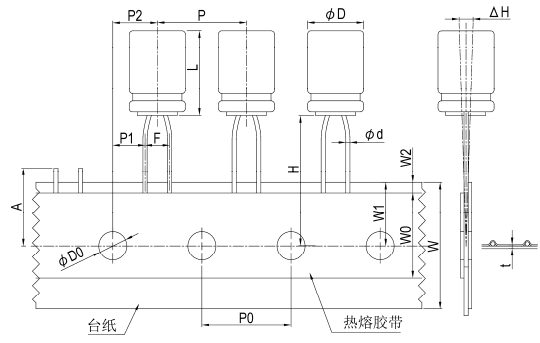

单位: 毫米

加工别 L 记号 I phi D	TA ¹								SA								SP							
	5 ²		7 ~ 9			≥ 11			5 ²		≥ 7		7 ~ 9		11.5 ~ 20		9 ~ 25							
	4 ³	5	6.3	8	5	6.3	8	5	6.3	8	4 ³	5	6.3	8	5 ⁴	6.3 ⁴	8	8	公差值 ¹	10	12.5	12.5	公差值	
phi d	0.45		0.5			0.6			0.45		0.5		0.6		± 0.05		0.6				± 0.05			
F	5.0				2.5				3.5		3.5		+0.8/-0.2		5.0				+0.8 / -0.2					
H	17.5			18.5			20.0			17.5			18.5			± 0.75		18.5				± 0.75		
H0	16.0				---				---				± 0.5				---				---			
P	12.7				12.7				12.7				± 1.0				12.7		25.4		15.0		± 1.0	
P0	12.7				12.7				± 0.2				12.7		12.7		15.0 ⁵		± 0.2 / ± 0.3 (*5)		± 0.7			
P1	3.85				5.1				4.6		4.6		± 0.5		3.85		3.85		5.0		± 0.7			
P2	6.35				6.35				± 1.0				6.35		6.35		7.5		± 1.3					
W	18.0				18.0				± 0.5				18.0				± 0.5		± 0.5					
W0	6.0		10.0			12.0			6.0		10.0		12.0		最小值		12.0				最小值			
W1	9.0				9.0				± 0.5				9.0				± 0.5		± 0.5					
W2	1.5				1.5				最大值				1.5				最大值		最大值					
A	11.0				11.0				最大值				11.0				最大值		最大值					
phi D0	4.0				4.0				± 0.2				4.0				± 0.2		± 0.2					
Delta H	0				0				± 1.0				0				± 1.0		± 1.0					
t	0.7				0.7				± 0.2				0.7				± 0.2		± 0.2					
适用图号	1								2		3		3		2		3		3		4		3	

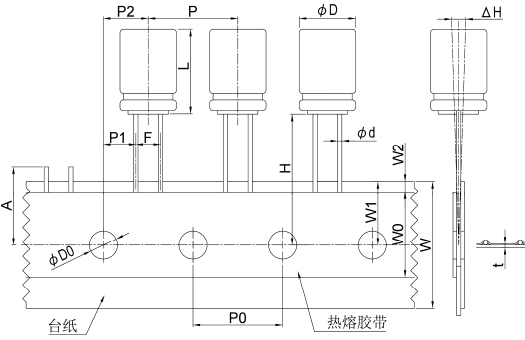
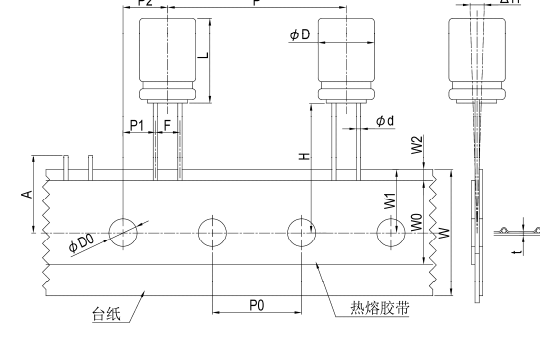
说明: *1: "TA"加工之寸法公差与"SA"相同。

*2: 制品尺寸 4 ~ 8 phi x 5L 之 W0 寸法最小亦可为 10.0 mm。

*3: 4 phi x 7L 之加工寸法与 4 phi 相同。

*4: "SA"加工: 5 ~ 6.3 phi x 11 ~ 15L 之 H 寸法为 18.5 mm。

*5: "SP"加工之 P0 寸法公差为 ± 0.3 mm; 如有其它贴带型式与寸法之需求, 请与我们连系。

包装型式与数量

图5 折迭式包装盒

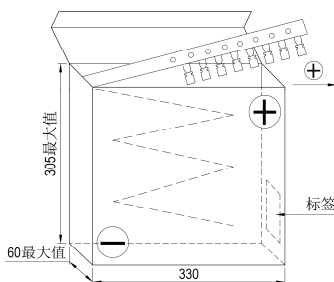

包装数量

单位: 个 / 盒

phi D (mm)	4	5	6.3	8	10	12.5
数量	2,500	2,000	2,000	1,000	500	300

注: 电容器是以正极引线为导向, 亦可依客户要求以负极引线为导向。